



Model shown

TELW150N112 - Elba Oval WiFi 500 W Black RAL 9005

ELECTRIC

TOWEL RAILS

Thanks to the perfect combination of style and smart functions, our towel rails are the ideal bathroom heating and drying solution.

Turn your bathroom into a space of well-being, where you can relax after an intense day's work.

Rointe electric towel rail comparison	50
D Series WiFi DIRECT	52
D Series RAL colour & special finishes WiFi DIRECT	54
Ocean WiFi DIRECT NEW!	56
Kyros	58
Syigma	60
Milano with heating fan	62
Elba Oval WiFi WiFi DIRECT	64
Elba Oval	66
Venezia Oval WiFi WiFi DIRECT	68
Towel rail accessories	70







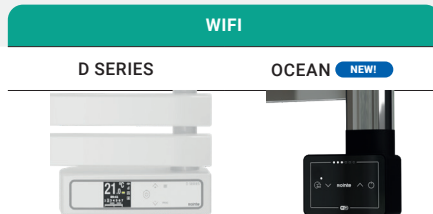































ELECTRIC TOWEL RAILS

COMPARISON TABLE:
CHARACTERISTICS

CHOOSE YOUR TOWEL RAIL
TO SUIT YOUR NEEDS



	D SERIES	OCEAN NEW!
Heating technology	Optimum Flux Tech	Optimum Flux Tech
Integrated communication module		
Remote control method	App	App
Artificial Intelligence Heating System		
Consumption and cost control		
Body material	Steel ST12	Steel ST12
Screen	TFT with customisable colour	-
Touch control panel		
Open Windows function		
Usage & limitation modes	User & Hotel modes	 via App
24/7 programming		 via App
Pre-installed programmes	-	4 via App
Early Start function	 via App	 via App
Boost function	15, 30, 60 or 120 minutes	15, 30, 45, 60, 90 or 120 minutes
Timer	-	-
Built-in heating fan	-	-
Nominal powers (W)	300 / 450 / 600 / 750	300 / 500 / 750 / 1.000
Available finishes		
Comfort	Controllability	
	User friendliness	

WIFI		NON WIFI		
OVAL WIFI	KYROS	SYGMA	MILANO	OVAL
				
Optimum Flux Tech	Optimum Flux Tech	Optimum Flux Tech	Optimum Flux Tech	Optimum Flux Tech
	-	-	-	-
App	Remote control	Remote control	-	Remote control
	-	-	-	-
	-	-	-	-
Steel ST12	Steel ST12	Steel ST12	Steel ST12	Steel ST12
-	TFT	TFT	LCD	-
	-	-		-
				
	User mode	-	-	-
via App				
via App	4	-	3	via Remote Control
4 via App	4	-	3	4 via Remote Control
	-	-	-	-
via App	-	-	-	-
15, 30, 45, 60, 90 or 120 minutes	15, 30, 60 or 120 minutes	120 minutes	-	15, 30, 45, 60, 90 or 120 minutes
-	-	-		-
-	-	-		-
300 / 500 / 750 / 1.000	300 / 500 / 750 / 1.000	300 / 500 / 750 / 1.000	500 + 1000	300 / 500 / 750 / 1.000
				
				
				

D SERIES

WiFi DIRECT

DIGITAL ELECTRIC TOWEL RAIL WITH WIFI & ARTIFICIAL INTELLIGENCE

CONTROL

- **WiFi Inside Module:** direct connection without gateways ¹.
- **Rointe Connect:** App for smartphone, tablet or PC.
- **Touch control panel** with TFT display.
- **3 modes:** **Comfort, Eco & Anti-Frost.**
- **Bluetooth pairing** in 3 easy steps.

SAVINGS

- **AIH System:** exclusive artificial intelligence system.
- Integrated consumption meter: **True Real Power** ².
- **Consumption and cost statistics** in the App with customisable electricity tariffs.
- Energy-saving functions: **Open Windows.**
- **Early Start function:** available from the App, the product determines the start-up time to optimise preheating.
- **Automated actions** based on geolocation.

TECHNOLOGY

- **Optimum Flux tech:** high heat transfer thermal fluid.
- High-sensitivity digital thermostat $\pm 0,1$ °C.
- **Secure communications** and personal data.

FUNCTIONALITY

- **24/7 programming** from the product and/or App.
- **Boost function:** 15, 30, 60 or 120 minutes.
- **User mode:** restricts the temperature range.
- **Hotel mode:** restricts temperatures and locks the panel.
- **2 lock modes:** from the product and/or App.
- **Customisable display colour & brightness** from the App.

DESIGN

- **Body made of steel ST12.**
- Collectors \varnothing 32 mm, rectangular tubes 20 x 40 mm.
- Cable (1,4 m) with outlet on the right-hand side.
- **Easy installation:** includes brackets, kit and template.



Model shown
DTN045SEN - D Series 450W Graphite textured



Energy saving functions

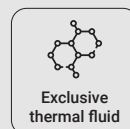

Exclusive thermal fluid



Artificial Intelligence

CONTROL

Scan and download the latest version of the Rointe Connect app

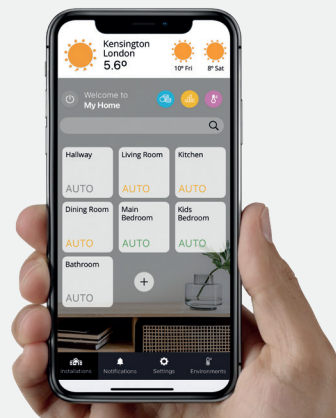

White finish



Chrome finish

TECHNICAL SPECIFICATIONS



MODELS	White	DTN030SEB	DTN045SEB	DTN060SEB	DTN075SEB
	Chrome	DTN030SEC	DTN045SEC	DTN060SEC	DTN075SEC
	Graphite	DTN030SEN	DTN045SEN	DTN060SEN	DTN075SEN
Number of tubes		13	17	21	25
Nominal power (W)	White / Graphite	300	450	600	750
	Chrome	300	300	450	600
Voltage (V)		220-240 V ~	220-240 V ~	220-240 V ~	220-240 V ~
Frequency (Hz)		50	50	50	50
Current (A)	White / Graphite	1,3	2,0	2,6	3,3
	Chrome	1,3	1,3	2,0	2,6
Protection		Class II	Class II	Class II	Class II
IP rating		IP44	IP44	IP44	IP44
Width x height (mm)		500 x 850	500 x 1.168	500 x 1.486	500 x 1.804
Depth (mm)		62	62	62	62
Installed depth (mm)		97	97	97	97
Packaged height x width x depth (mm)		1.000 x 550 x 100	1.350 x 550 x 100	1.750 x 550 x 100	2.000 x 550 x 100
Weight (Kg)		15,4	19,7	25,3	29,9
Packaged weight (Kg)		17,0	22,0	28,0	33,0
Recommended area (m ²)		Up to 3	Up to 4,5	Up to 6	Up to 7,5
Included with product	Type C plug (1.4 m), brackets, installation kit, template and user manual				
Compatible accessories	-				
Number of brackets		4	4	4	4
Finishes	White RAL 9016 / Chrome / Graphite textured				
EAN13	White	8436045912671	8436045912688	8436045912695	8436045912701
	Chrome	8436045912596	8436045912602	8436045912619	8436045912626
	Graphite	8436045912633	8436045912640	8436045912657	8436045912664
T.P. ³	White				
	Chrome				
	Graphite				



WiFi DIRECT

Direct connection to WiFi without gateways or smartboxes.



ENERGY SAVINGS

Exclusive functions that save energy and money.



CONTROL AT YOUR FINGERTIPS

Control your heating and consumption whenever and wherever you want.

DIAGRAMS

Dimensions in mm.

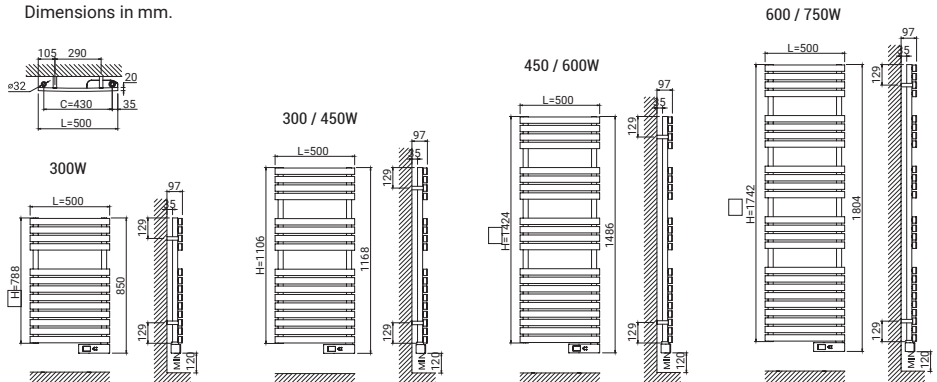

1) Compatible with 2.4 GHz WiFi networks. 2) The figure may vary depending on the circumstances of the electrical installation. 3) Price excluding VAT.

D SERIES

RAL COLOURS & SPECIAL FINISHES
AVAILABLE



OYSTER WHITE RAL 1013 text.

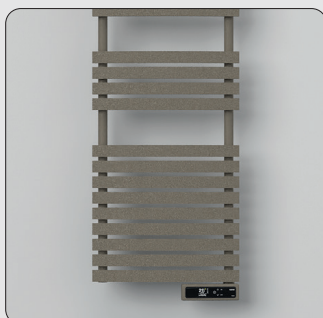

PEARL BEIGE RAL 1035 text.



AGATE GREY RAL 7038 text.



TRAFFIC GREY RAL 7042 text.



TARPAULIN GREY RAL 7010 text.



AMAZON - Green oxide text.



DETROIT - Brown oxide text.



MALDIVES - Black copper

TECHNICAL SPECIFICATIONS



MODELS	RAL 1013	DTN30R1013T	DTN45R1013T	DTN60R1013T	DTN75R1013T	
		RAL 1035	DTN30R1035T	DTN45R1035T	DTN60R1035T	DTN75R1035T
		RAL 7010	DTN30R7010T	DTN45R7010T	DTN60R7010T	DTN75R7010T
		RAL 7038	DTN30R7038T	DTN45R7038T	DTN60R7038T	DTN75R7038T
		RAL 7042	DTN30R7042T	DTN45R7042T	DTN60R7042T	DTN75R7042T
		Detroit	DTN030AOL	DTN045AOL	DTN060AOL	DTN075AOL
		Amazon	DTN030AOV	DTN045AOV	DTN060AOV	DTN075AOV
		Maldives	DTN030ACM	DTN045ACM	DTN060ACM	DTN075ACM
Number of tubes		13	17	21	25	
Nominal power (W)		300	450	600	750	
Voltage (V)		220-240 V ~	220-240 V ~	220-240 V ~	220-240 V ~	
Frequency (Hz)		50	50	50	50	
Current (A)		1,3	2,0	2,6	3,3	
Protection		Class II	Class II	Class II	Class II	
IP rating		IP44	IP44	IP44	IP44	
Width x height (mm)		500 x 850	500 x 1.168	500 x 1.486	500 x 1.804	
Depth (mm)		62	62	62	62	
Installed depth (mm)		97	97	97	97	
Packaged height x width x depth (mm)		1.000 x 550 x 100	1.350 x 550 x 100	1.750 x 550 x 100	2.000 x 550 x 100	
Weight (Kg)		15,4	19,7	25,3	29,9	
Packaged weight (Kg)		17,0	22,0	28,0	33,0	
Recommended area (m ²)		Up to 3	Up to 4,5	Up to 6	Up to 7,5	
Included with product		Type C plug (1.4 m), brackets, installation kit, template & manual				
Compatible accessories		-				
Number of brackets		4	4	4	4	
EAN13	RAL 1013	8435556120063	8435556120070	8435556120087	8435556120094	
	RAL 1035	8435556120223	8435556120230	8435556120247	8435556120254	
	RAL 7010	8435556120186	8435556120193	8435556120209	8435556120216	
	RAL 7038	8435556120346	8435556120353	8435556120360	8435556120377	
	RAL 7042	8435556120308	8435556120315	8435556120322	8435556120339	
	Detroit	8436580774093	8436580774109	8436580774116	8436580774123	
	Amazon	8436580774055	8436580774062	8436580774079	8436580774086	
	Maldives	8436580774017	8436580774024	8436580774031	8436580774048	
	T.P. ¹	RAL 1013				
		RAL 1035				
RAL 7010						
RAL 7038						
RAL 7042						
Detroit						
Amazon						
Maldives						

1) Price excluding VAT.

Product compatible with 2.4 GHz WiFi networks.

The catalogue printing process does not allow the exact reproduction of the tones, brightness and colours of the radiators, therefore the images shown are indicative and may differ slightly from the product received. Please note that the D Series RAL Colours & Special finishes products have a lead time of 4 to 6 weeks.

NEW PRODUCT!

OCEAN

WiFi DIRECT

DIGITAL ELECTRIC TOWEL RAIL WITH WIFI & ARTIFICIAL INTELLIGENCE

CONTROL

- **WiFi Inside Module:** direct connection without gateways ¹.
- **Rointe Connect:** App for smartphone, tablet or PC.
- **Touch control panel with 4 buttons** and LED indicators.
- **6 different temperature modes.**
- **Bluetooth pairing** in 3 easy steps.

SAVINGS

- **AIH System:** exclusive artificial intelligence system.
- Integrated consumption meter: **True Real Power** ².
- **Consumption and cost statistics** in the App with customisable electricity tariffs.
- Energy-saving functions: **Open Windows.**
- **Early Start function:** available from the App, the product determines the start-up time to optimise preheating.
- **Automated actions** based on geolocation.

TECHNOLOGY

- **Optimum Flux tech:** high heat transfer thermal fluid.
- High-sensitivity digital thermostat $\pm 0,1$ °C.
- **Secure communications** and personal data.

FUNCTIONALITY

- **24/7 programming** from the App.
- **Boost function:** 15, 30, 45, 60, 90 or 120 minutes.
- **User mode:** restricts the temperature range.
- **Hotel mode:** restricts temperatures and locks the panel.
- **2 lock modes:** from the product and/or App.

DESIGN

- Body made of **steel ST12.**
- Collectors 30 x 40 mm and tubes 10 x 40 mm.
- Cable (1,4 m) with outlet on the right-hand side.
- **Easy installation:** includes brackets, kit and template.



Model shown

TON030SEN - Ocean WiFi 300W Black



Energy saving functions

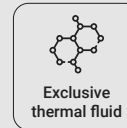

Exclusive thermal fluid

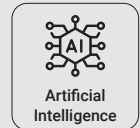

Artificial Intelligence

CONTROL

Scan and download the latest version of the Rointe Connect app

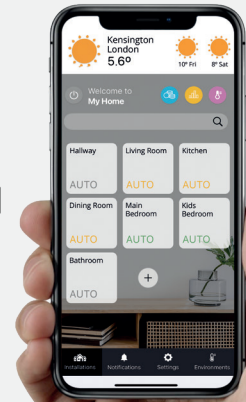

White finish



Chrome finish

TECHNICAL SPECIFICATIONS



MODELS	White	TON030SEB	TON050SEB	TON075SEB	TON100SEB
	Chrome	TON030SEC	TON050SEC	TON075SEC	TON100SEC
	Black	TON030SEN	TON050SEN	TON075SEN	TON100SEN
Number of tubes		8	12	16	18
Nominal power (W)	White / Black	300	500	750	1.000
	Chrome	300	300	500	750
Voltage (V)		220-240 V ~	220-240 V ~	220-240 V ~	220-240 V ~
Frequency (Hz)		50	50	50	50
Current (A)	White / Black	1,3	2,2	3,3	4,3
	Chrome	1,3	1,3	2,2	3,3
Protection		Class II	Class II	Class II	Class II
IP rating		IP44	IP44	IP44	IP44
Width x height (mm)		500 x 880	500 x 1.280	500 x 1.680	500 x 1.880
Depth (mm)		30	30	30	30
Installed depth (mm)		85	85	85	85
Packaged height x width x depth (mm)		1.000 x 550 x 100	1.350 x 550 x 100	1.750 x 550 x 100	2.000 x 550 x 100
Weight (Kg)		9,4	11,8	17,4	19,0
Packaged weight (Kg)		11,0	14,0	20,0	22,0
Recommended area (m ²)		Up to 3	Up to 5	Up to 7,5	Up to 10
Included with product	Type C plug (1.4 m), brackets, installation kit, template and user manual				
Compatible accessories	-				
Number of brackets		4	4	4	4
Finishes		White RAL 9016 / Chrome / Black			
	White	8435556158585	8435556158592	8435556158608	8435556158615
	Chrome	8435556158622	8435556158639	8436045917546	8436045917553
	Black	8435556158745	8435556158752	8435556158769	8435556158776
T.P. ⁴	White				
	Chrome				
	Black				



WiFi DIRECT

Direct connection to WiFi without gateways or smartboxes.



ENERGY SAVINGS

Exclusive functions that save energy and money.



CONTROL AT YOUR FINGERTIPS

Control your heating and consumption whenever and wherever you want.

DIAGRAMS

Dimensions in mm.

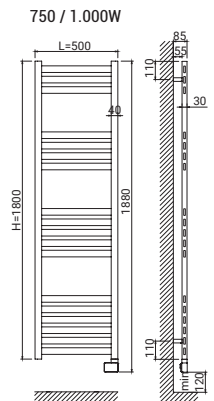
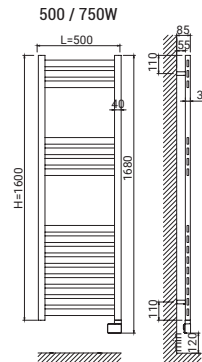
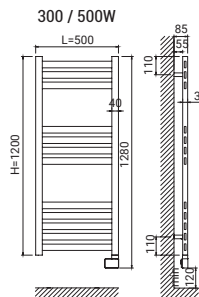
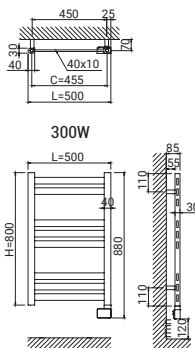

1) Compatible with 2.4 GHz WiFi networks. 2) The figure may vary depending on the circumstances of the electrical installation. 3) This product complies with the ECODESIGN standard when controlled via the App. 4) Price excluding VAT.

NEW FINISH!

KYROS

DIGITAL ELECTRIC TOWEL RAIL WITH PRE-INSTALLED PROGRAMMES

CONTROL

- 5-button mechanical control panel and TFT display.
- 3 modes: **Comfort, Eco & Anti-Frost.**
- Compatible with remote controls **AIR & BASIC Control** (sold separately).

SAVINGS

- Energy-saving functions: **Open Windows.**

TECHNOLOGY

- High-sensitivity digital thermostat $\pm 0,1$ °C.
- **Optimum Flux tech:** high heat transfer thermal fluid.

FUNCTIONALITY

- **24/7 programming** from the product and/or remote.
- **4 weekly programmes** pre-installed in the product.
- **Boost function:** 15, 30, 60, or 120 minutes.
- **2 lock modes:** from the product and/or remote control.

DESIGN

- Body made of **steel ST12.**
- D shape collectors 30 x 40 mm and flat design tubes 10 x 40 mm.
- Cable (1,4 m) with outlet on the right-hand side.
- **Easy installation:** includes brackets, kit and template.



Model shown
KTN050SEB3 - Kyros 500W White RAL 9016

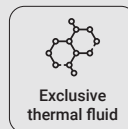

Black finish



Chrome finish

CONTROL

Compatible with
remote controls
AIR Control & BASIC Control
available on
page 94.



TECHNICAL SPECIFICATIONS



MODELS	White	KTN030SEB3	KTN050SEB3	KTN075SEB3	KTN100SEB3
	Chrome	KTN030SEC3	KTN050SEC3	KTN075SEC3	KTN100SEC3
	Black	KTN030SEN3	KTN050SEN3	KTN075SEN3	KTN100SEN3
Number of tubes		8	12	16	18
Nominal power (W)	White / Black	300	500	750	1.000
	Chrome	300	300	500	750
Voltage (V)		220-240 V ~	220-240 V ~	220-240 V ~	220-240 V ~
Frequency (Hz)		50	50	50	50
Current (A)	White / Black	1,3	2,2	3,3	4,3
	Chrome	1,3	1,3	2,2	3,3
Protection		Class II	Class II	Class II	Class II
IP rating		IP44	IP44	IP44	IP44
Width x height (mm)		500 x 900	500 x 1.300	500 x 1.700	500 x 1.900
Depth (mm)		30	30	30	30
Installed depth (mm)		85	85	85	85
Packaged height x width x depth (mm)		1.000 x 550 x 100	1.350 x 550 x 100	1.750 x 550 x 100	2.000 x 550 x 100
Weight (Kg)		9,4	11,8	17,4	19,0
Packaged weight (Kg)		11,0	14,0	20,0	22,0
Recommended area (m ²)		Up to 3	Up to 5	Up to 7,5	Up to 10
Included with product		Type C plug (1.4 m), brackets, installation kit, template and user manual			
Compatible accessories		-			
Number of brackets		4	4	4	4
Finishes		White RAL 9016 / Chrome / Black			
EAN13	White	8436045917560	8436045917577	8436045917584	8436045917591
	Chrome	8436045917522	8436045917539	8436045917546	8436045917553
	Black	8435556158783	8435556158790	8435556158806	8435556158813
T.P. ¹	White				
	Chrome				
	Black				



EASY TO INSTALL AND USE

Easy to use with a simplified programming process.



ENERGY SAVINGS

Open Windows function that help you save energy and money.



REMOTE CONTROL

Control your heating with infrared remote controls.

DIAGRAMS

Dimensions in mm.

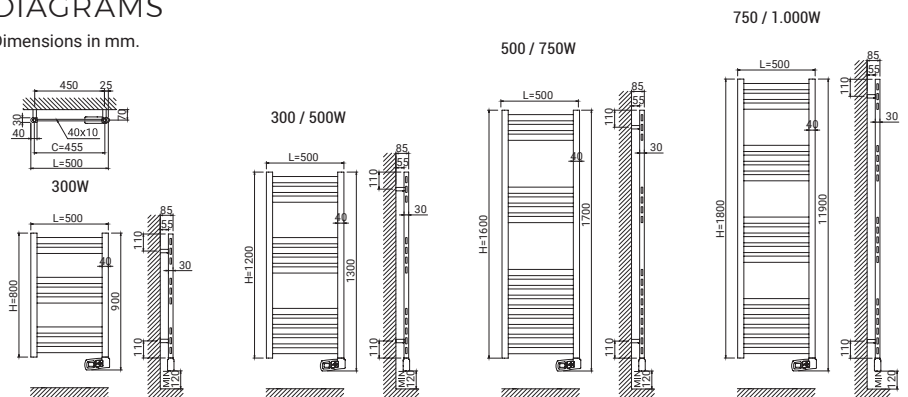

1) Price excluding VAT.

SYGMA

DIGITAL ELECTRIC TOWEL RAIL WITH 24/7 PROGRAMMING

CONTROL

- 5-button mechanical control panel and TFT display.
- 3 modes: **Comfort, Eco & Anti-Frost.**
- Compatible with remote controls **AIR & BASIC Control** (sold separately).

SAVINGS

- Energy-saving functions: **Open Windows.**

TECHNOLOGY

- High-sensitivity digital thermostat $\pm 0,1$ °C.
- **Optimum Flux tech:** high heat transfer thermal fluid.

FUNCTIONALITY

- **24/7 programming** from the product/remote control.
- **Boost function:** 15, 30, 60, or 120 minutes.
- **2 lock modes:** from the product and/or remote control.

DESIGN

- Body made of **steel ST12.**
- Collectors 30 x 40 mm and tubes \varnothing 22 mm.
- Cable (1,4 m) with outlet on the right-hand side.
- **Easy installation:** includes brackets, kit and template.
- **Accessories like racks and hooks** for Rointe towel rails are available on page 70.



Model shown
STN030SEC3 - Sygma 300W Chrome



Energy saving functions

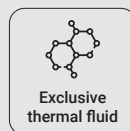

Exclusive thermal fluid



24/7 programming



White finish



Chrome finish

CONTROL

Compatible with
remote controls
AIR Control & BASIC Control
available on
page 94.



TECHNICAL SPECIFICATIONS



MODELS	White	STN030SEB3	STN050SEB3	STN075SEB3	STN100SEB3
	Chrome	STN030SEC3	STN050SEC3	STN075SEC3	STN100SEC3
Number of tubes		12	19	26	34
Nominal power (W)	White	300	500	750	1.000
	Chrome	300	300	500	750
Voltage (V)		220-240 V ~	220-240 V ~	220-240 V ~	220-240 V ~
Frequency (Hz)		50	50	50	50
Current (A)	White	1,3	2,2	3,3	4,3
	Chrome	1,3	1,3	2,2	3,3
Protection		Class II	Class II	Class II	Class II
IP rating		IP44	IP44	IP44	IP44
Width x height (mm)		500 x 900	500 x 1.300	500 x 1.700	500 x 1.900
Depth (mm)		60	60	60	60
Installed depth (mm)		100	100	100	100
Packaged height x width x depth (mm)		1.000 x 550 x 100	1.350 x 550 x 100	1.750 x 550 x 100	2.000 x 550 x 100
Weight (Kg)		10,6	15,9	20,6	26,2
Packaged weight (Kg)		12,0	18,0	23,0	29,0
Recommended area (m ²)		Up to 3	Up to 5	Up to 7,5	Up to 10
Included with product		Type C plug (1.4 m), brackets, installation kit, template and user manual			
Compatible accessories		Hooks - RSH*002 / Racks RSR*003			
Number of brackets		3	3	3	3
Finishes		White RAL 9016 / Chrome			
EAN13	White	8436045911834	8436045911841	8436045911858	8436045911865
	Chrome	8436045911674	8436045911681	8436045911698	8436045911704
T.P. ¹	White				
	Chrome				



EASY TO INSTALL AND USE

Easy to use with a simplified programming process.



ENERGY SAVINGS

Open Windows function that help you save energy and money.



REMOTE CONTROL

Control your heating with infrared remote controls.

DIAGRAMS

Dimensions in mm.

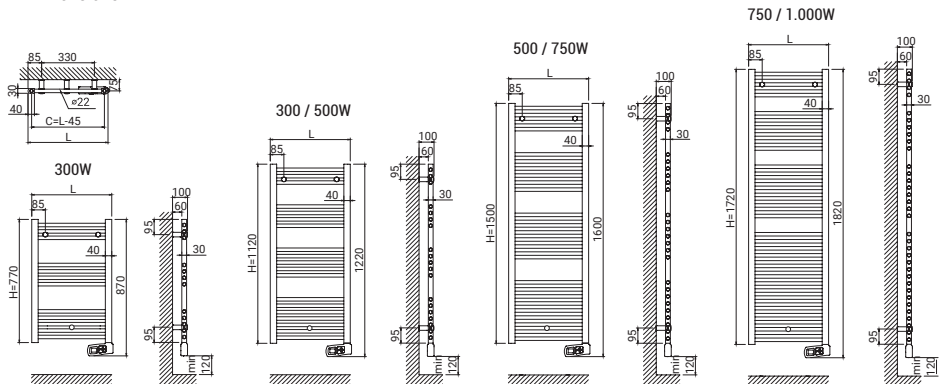

1) Price excluding VAT.

PRODUCT
VIDEO



MILANO

DIGITAL ELECTRIC TOWEL RAIL WITH BUILT-IN HEATING FAN

CONTROL

- Touch control panel with 5 buttons and LCD screen.
- 3 modes: **Comfort**, **Eco** & **Anti-Frost**.

SAVINGS

- Exclusive technology that **reduces the average power rating** required to maintain comfort by **up to 70%**¹.
- Energy-saving functions: **Open Windows**.

TECHNOLOGY

- High-sensitivity digital thermostat $\pm 0,1$ °C.
- **Optimum Flux tech**: high heat transfer thermal fluid.

FUNCTIONALITY

- 24/7 programming.
- 3 preset weekly programmes installed and ready to use.
- **Timer**: up to 9 hours of continuous operation.

DESIGN

- Body made of **steel ST12**.
- Collectors 30 x 40 mm and tubes \varnothing 22 mm.
- Cable (1,4 m) with outlet on the right-hand side.
- **Easy installation**: includes brackets, kit and template.
- **Accessories like racks and hooks** for Rointe towel rails are available on page 70.

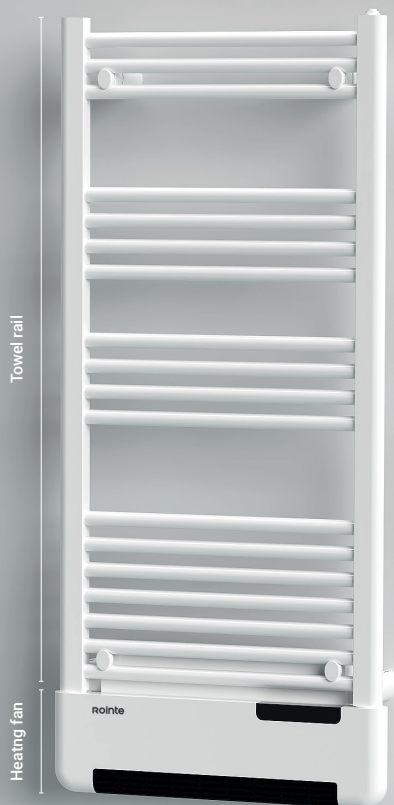

Model shown

TMILN50B115 - Milano 1.500W White RAL 9016



Energy saving
functions



Exclusive
thermal fluid



24/7
programming

DID YOU KNOW...

The exclusive low consumption technology in Rointe MILANO towel rails, tested in a climatic chamber, **reduces the average nominal power required to maintain the best comfort in your bathroom by up to 70%**¹.

¹) According to tests carried out by Rointe to heat a 10 m² room to 21°C for a period of 12 hours.



TECHNICAL SPECIFICATIONS



MODELS	TMLN50B115	
Number of tubes	18	
Nominal power (W)	Towel rail	500
	Heating fan	1.000
Voltage (V)	220-240	
Frequency (Hz)	50	
Current (A)	Towel rail	2,2
	Heating fan	4,4
Protection	Class II	
IP rating	IP24	
Width x height (mm)	500 x 1.150	
Depth (mm)	30	
Installed depth (mm)	140	
Packaged height x width x depth (mm)	1.520 x 570 x 70	
Weight (Kg)	9,9	
Packaged weight (Kg)	11,5	
Recommended area (m ²)	Up to 10	
Included with product	Type C plug (1.4 m), brackets, installation kit, template and user manual	
Compatible accessories	Hooks - RSH*002 / Racks RSR*003	
Number of brackets	4	
Finishes	White RAL 9016	
EAN13	8435556147626	
T.P. ¹	479 €	

DIAGRAMS

Dimensions in mm.

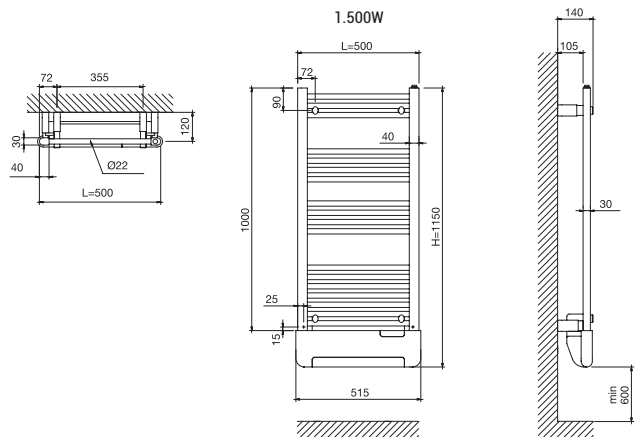

1) Price excluding VAT.

ELBA *Oval WiFi*

WiFi DIRECT

PRODUCT VIDEO



DIGITAL ELECTRIC TOWEL RAIL WITH WIFI & ARTIFICIAL INTELLIGENCE

CONTROL

- **WiFi Inside Module:** direct connection without gateways ¹.
- **Rointe Connect:** App for smartphone, tablet or PC.
- **Touch control panel with 4 buttons** and LED indicators.
- **6 different temperature modes.**
- **Bluetooth pairing** in 3 easy steps.

SAVINGS

- **AIH System:** exclusive artificial intelligence system.
- Integrated consumption meter: **True Real Power** ².
- **Consumption and cost statistics** in the App with customisable electricity tariffs.
- Energy-saving functions: **Open Windows.**
- **Early Start function:** available from the App, the product determines the start-up time to optimise preheating.
- **Automated actions** based on geolocation.

TECHNOLOGY

- **Optimum Flux tech:** high heat transfer thermal fluid.
- High-sensitivity digital thermostat $\pm 0,1$ °C.
- **Secure communications** and personal data.

FUNCTIONALITY

- **24/7 programming** from the App.
- **Boost function:** 15, 30, 45, 60, 90 or 120 minutes.
- **User mode:** restricts the temperature range.
- **Hotel mode:** restricts temperatures and locks the panel.
- **2 lock modes:** from the product and/or App.

DESIGN

- Body made of steel ST12.
- Collectors 30 x 40 mm and tubes \varnothing 22 mm.
- Cable (1,4 m) with outlet on the right-hand side.
- **Easy installation:** includes brackets, kit and template.
- **Accessories like racks and hooks** for Rointe towel rails are available on page 70.



Model shown

TELWN50N112 - Elba Oval WiFi 500W Black RAL 9005



Energy saving functions

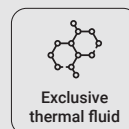

Exclusive thermal fluid



Artificial Intelligence

CONTROL

Scan and download the latest version of the Rointe Connect app



White finish

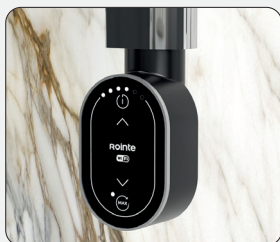

Chrome finish

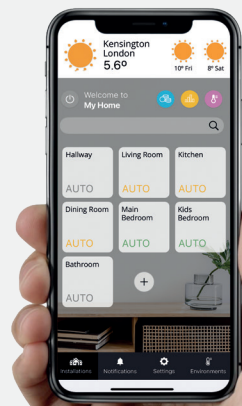

TECHNICAL SPECIFICATIONS



MODELS	White	TELWN50B077	TELWN50B112	TELWN50B150	TELWN50B172
	Chrome	TELWN50C077	TELWN50C112	TELWN50C150	TELWN50C172
	Black	TELWN50N077	TELWN50N112	TELWN50N150	TELWN50N172
Number of tubes		12	19	26	34
Nominal power (W)	White / Black	300	500	750	1.000
	Chrome	300	300	500	750
Voltage (V)		220-240 V ~	220-240 V ~	220-240 V ~	220-240 V ~
Frequency (Hz)		50	50	50	50
Current (A)	White / Black	1,3	2,2	3,3	4,3
	Chrome	1,3	1,3	2,2	3,3
Protection		Class II	Class II	Class II	Class II
IP rating		IP44	IP44	IP44	IP44
Width x height (mm)		500 x 865	500 x 1.215	500 x 1.595	500 x 1.815
Depth (mm)		30	30	30	30
Installed depth (mm)		100	100	100	100
Packaged height x width x depth (mm)		970 x 620 x 100	1.320 x 620 x 100	1.700 x 620 x 100	1.920 x 620 x 100
Weight (Kg)		7,4	11,6	14,6	18,1
Packaged weight (Kg)		9,0	13,8	17,1	21,0
Recommended area (m ²)		Up to 3	Up to 5	Up to 7,5	Up to 10
Included with product	Type C plug (1.4 m), brackets, installation kit, template and user manual				
Compatible accessories	Hooks - RSH*002 / Racks RSR*003				
Number of brackets		3	3	3	3
Finishes	White RAL 9016 / Chrome / Black RAL 9005				
EAN13	White	8435556146377	8435556146384	8435556146391	8435556146407
	Chrome	8435556146414	8435556146421	8435556146438	8435556146445
	Black	8435556146452	8435556146469	8435556158882	8435556158899
T.P. ⁴	White				
	Chrome				
	Black				

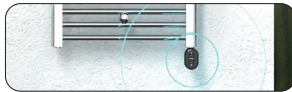

WiFi DIRECT

Direct connection to WiFi without gateways or smartboxes.



ENERGY SAVINGS

Exclusive functions that save energy and money.



CONTROL AT YOUR FINGERTIPS

Control your heating and consumption whenever and wherever you want.

DIAGRAMS

Dimensions in mm.

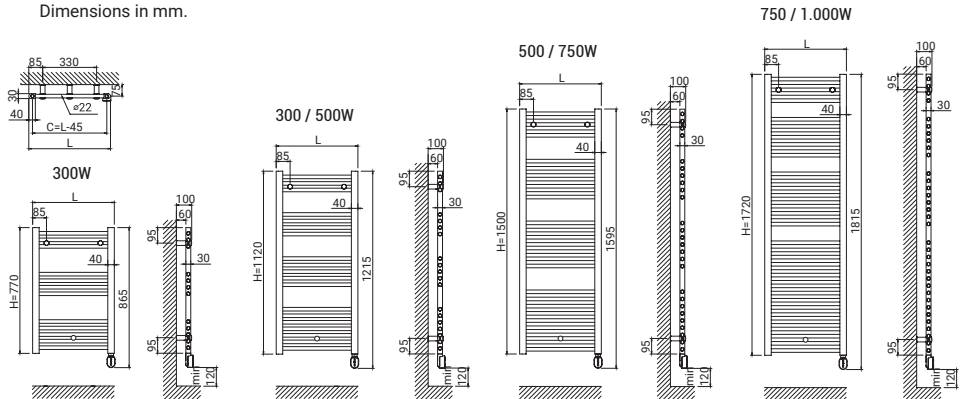

1) Compatible with 2.4 GHz WiFi networks. 2) The figure may vary depending on the circumstances of the electrical installation. 3) This product complies with the ECODESIGN standard when controlled via the App. 4) Price excluding VAT.

PRODUCT
VIDEO



ELBA *Oval*

DIGITAL ELECTRIC TOWEL RAIL WITH 24/7 PROGRAMMING

CONTROL

- 4-button mechanical panel and LED indicators.
- 6 different temperature modes.
- Compatible with remote controls AIR & BASIC Control (sold separately).

SAVINGS

- Energy-saving functions: Open Windows.

TECHNOLOGY

- High-sensitivity digital thermostat.
- Optimum Flux tech: high heat transfer thermal fluid.

FUNCTIONALITY

- 24/7 programming from the product/remote control.
- Boost function: 15, 30, 45, 60, 90 or 120 minutes at maximum power.
- 2 lock modes: from the product and/or remote control.

DESIGN

- Body made of steel ST12.
- Collectors 30 x 40 mm and tubes \varnothing 22 mm.
- Cable (1,4 m) with outlet on the right-hand side.
- Easy installation: includes brackets, kit and template.
- Accessories are available on page 70.



Model shown

TELVN50B112 - Elba Oval 500W White RAL 9016



Energy saving
functions



Exclusive
thermal fluid



24/7
programming



White finish



Black / chrome finish

CONTROL

Compatible with
remote controls
AIR Control & BASIC
Control available on
page 94.



TECHNICAL SPECIFICATIONS



MODELS	White	TELVN50B077	TELVN50B112	TELVN50B150	TELVN50B172
	Chrome	TELVN50C077	TELVN50C112	TELVN50C150	TELVN50C172
	Black	TELVN50N077	TELVN50N112	TELVN50N150	TELVN50N172
Number of tubes		12	19	26	34
Nominal power (W)	Wh. / Bl.	300	500	750	1.000
	Chrome	300	300	500	750
Voltage (V)		220-240 V ~	220-240 V ~	220-240 V ~	220-240 V ~
Frequency (Hz)		50	50	50	50
Current (A)	Wh. / Bl.	1,3	2,2	3,3	4,4
	Chrome	1,3	1,3	2,2	3,3
Protection		Class II	Class II	Class II	Class II
IP rating		IP44	IP44	IP44	IP44
Width x height (mm)		500 x 865	500 x 1.215	500 x 1.595	500 x 1.815
Depth (mm)		30	30	30	30
Installed depth (mm)		100	100	100	100
Packaged h x w x d (mm)		970 x 620 x 100	1.320 x 620 x 100	1.700 x 620 x 100	1.920 x 620 x 100
Weight (Kg)		7,4	11,6	14,6	18,1
Packaged weight (Kg)		9,0	13,8	17,1	21,0
Recommended area (m ²)		Up to 3	Up to 5	Up to 7,5	Up to 10
Included with product	Type C plug (1.4 m), brackets, installation kit, template and user manual				
Compatible accessories	Hooks - RSH*002 / Racks RSR*003				
Number of brackets		3	3	3	3
Finishes	White RAL 9016 / Chrome / Black RAL 9005				
EAN13	White	8435556131311	8435556114246	8435556131335	8435556131342
	Chrome	8435556131359	8435556131366	8435556131373	8435556131380
	Black	8435556114277	8435556124672	8435556158868	8435556158875
T.P. ²	White				
	Chrome				
	Black				



EASY TO INSTALL AND USE
Easy to use with a simplified programming process.



ENERGY SAVINGS
Open Windows function that help you save energy and money.



REMOTE CONTROL¹
Control your heating with infrared remote controls.

DIAGRAMS

Dimensions in mm.

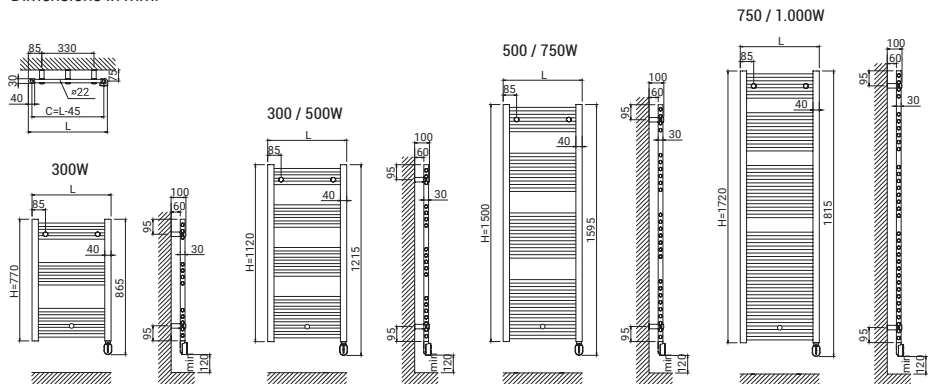

1) This product complies with the ECODSIGN standard when controlled by a Rointe AIR or BASIC Control remote. 2) Price excluding VAT.

VENEZIA

Oval Wi-Fi

WiFi DIRECT

DIGITAL ELECTRIC TOWEL RAIL WITH WIFI & ARTIFICIAL INTELLIGENCE

CONTROL

- **WiFi Inside Module:** direct connection without gateways ¹.
- **Rointe Connect:** App for smartphone, tablet or PC.
- **Touch control panel with 4 buttons** and LED indicators.
- **6 different temperature modes.**
- **Bluetooth pairing** in 3 easy steps.

SAVINGS

- **AIH System:** exclusive artificial intelligence system.
- Integrated consumption meter: **True Real Power** ².
- **Consumption and cost statistics** in the App with customisable electricity tariffs.
- Energy-saving functions: **Open Windows.**
- **Early Start function:** available from the App, the product determines the start-up time to optimise preheating.
- **Automated actions** based on geolocation.

TECHNOLOGY

- **Optimum Flux tech:** high heat transfer thermal fluid.
- High-sensitivity digital thermostat $\pm 0,1$ °C.
- **Secure communications** and personal data.

FUNCTIONALITY

- **24/7 programming** from the App.
- **Boost function:** 15, 30, 45, 60, 90 or 120 minutes.
- **User mode:** restricts the temperature range.
- **Hotel mode:** restricts temperatures and locks the panel.
- **2 lock modes:** from the product and/or App.

DESIGN

- Body made of **steel ST12.**
- Collectors 30 x 30 mm and tubes 30 x 10 mm.
- Cable (1,4 m) with outlet on the right-hand side.
- **Easy installation:** includes brackets, kit and template.



White finish



Chrome finish



Model shown

TVEWN50N120 - Venezia Oval Wi-Fi 500W Graphite textured

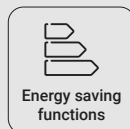

Energy saving functions

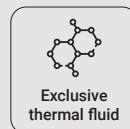

Exclusive thermal fluid



Artificial Intelligence

CONTROL

Scan and download the latest version of the Rointe Connect app

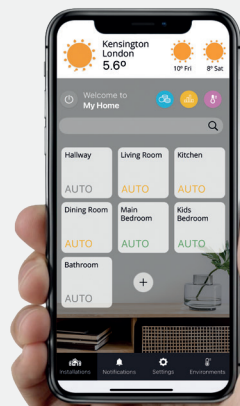

TECHNICAL SPECIFICATIONS



MODELS	White	TVEWN50B077	TVEWN50B120
	Graphite	TVEWN50N077	TVEWN50N120
Number of tubes	11		16
Nominal power (W)	300		500
Voltage (V)	220-240 V ~		220-240 V ~
Frequency (Hz)	50		50
Current (A)	1,3		2,2
Protection	Class II		Class II
IP rating	IP44		IP44
Width x height (mm)	500 x 870		500 x 1.295
Depth (mm)	50		50
Installed depth (mm)	105		105
Packaged height x width x depth (mm)	980 x 550 x 100		1.380 x 550 x 100
Weight (Kg)	10,0		15,5
Packaged weight (Kg)	11,7		17,8
Recommended area (m ²)	Up to 3		Up to 5
Included with product	Type C plug (1.4 m), brackets, installation kit, template and user manual		
Compatible accessories	-		
Number of brackets	4		4
Finishes	White RAL 9016 / Graphite textured		
EAN13	White	8435556146636	8435556146643
	Graphite	8435556146674	8435556146681
T.P. ⁴	White		
	Graphite		



WiFi DIRECT

Direct connection to WiFi without gateways or smartboxes.



ENERGY SAVINGS

Exclusive functions that save energy and money.



CONTROL AT YOUR FINGERTIPS

Control your heating and consumption whenever and wherever you want.

DIAGRAMS

Dimensions in mm.

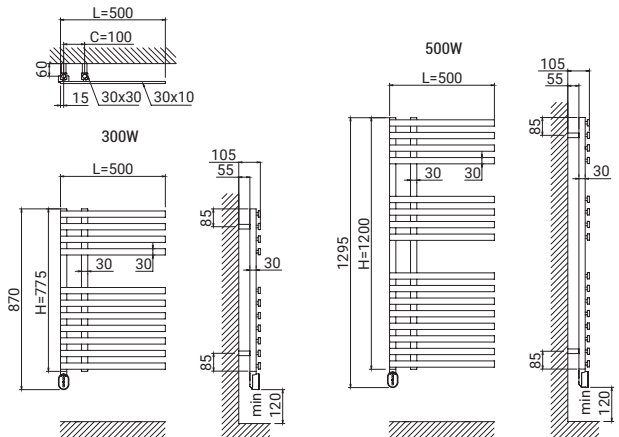

1) Compatible with 2.4 GHz WiFi networks. 2) The figure may vary depending on the circumstances of the electrical installation. 3) This product complies with the ECODESIGN standard when controlled via the App. 4) Price excluding VAT.

ACCESSORIES

FOR ROINTE
ELECTRIC TOWEL RAILS



HOOKS

This accessory allows you to extend the towel rail capacity by making it easier to place more towels and bath linen on it.

It's important not to exceed the maximum supported weight of 1 Kg per unit.

Available in 3 finishes: White, Chrome and Black.

MODELS	White	RSHW002
	Chrome	RSHC002
	Black	RSHB002
Units per pack	2	
Length x height (mm)	35 x 70	
Compatible with	Sygma, Milano & Elba	
Finishes	White RAL 9010 / Chrome / Graphite	
EAN13	White	8436045917010
	Chrome	8436045917027
	Black	8436045917041
T.P. ³	White	
	Chrome	
	Black	



Model shown
RSHW002



Model shown
RSHC002



Model shown
RSHB002

1) Price excluding VAT.



RACKS

This accessory allows more towels to be placed on the product, without exceeding the maximum supported weight.

The extra space between the wet towel and the towel rail also facilitates faster drying.

Available in 3 finishes: White, Chrome and Graphite.

MODELS	White	RSRW003
	Chrome	RSRC003
	Black	RSRB003
Units per pack	1	
Length x height (mm)	410 x 170	
Compatible with	Sygma, Milano & Elba	
Finishes	White RAL 9010 / Chrome / Graphite	
EAN13	White	8435556138549
	Chrome	8435556138563
	Black	8435556138556
T.P. ³	White	
	Chrome	
	Black	



Model shown
RSRW003



Model shown
RSRC003



Model shown
RSRB003

1) Price excluding VAT.